

TECHNICAL NOTE

Minimizing Buckling of Wood Structural Panels

Form D481P

July 2024

Buckling of wood structural panel sheathing such as plywood or oriented strand board (OSB) occasionally results when increased moisture conditions cause the wood to expand. Such buckling may occur between supports or between nails along supports. Although structural properties are unaffected, the waviness affects the building's appearance and may lead to complaints. Builders can significantly reduce the potential for buckling by ensuring minimal moisture-content increase in service and/or providing for its natural effects.

Mechanism of Buckling

All wood-based products absorb moisture from or give up moisture to the environment until they reach a moisture content in equilibrium with their surroundings. This results in swelling or shrinking of the wood. For solid wood, this expansion is 20 to 40 times as great across the grain as along the grain. Structural panels have good dimensional stability because the tendency of individual veneers or strands to swell or shrink crosswise is greatly restricted by the adjacent veneers or strands.

In typical sheathing applications, relative humidity might vary between 40% and 80%, with corresponding equilibrium moisture content of the panels ranging between 6% and 14%. Total dimensional change of an unrestrained 48 inches x 96 inches panel exposed to this range of conditions typically averages 1/8 inch in width or length. If the panel actually gets wet, dimensional change could be slightly greater. Dimensional changes in installed panels is partially restrained by fasteners and framing.

The tendency of expansion to cause buckling in structural panels is related to mechanical properties, physical properties and natural characteristics of wood. It is also a function of not spacing panel ends and edges to allow for expansion. Mechanical properties such as panel stiffness relative to the length of span are important. For a given span, a thin panel has a greater

tendency to buckle upon expansion than a thicker panel. Physical properties and characteristics of the panel include the natural growth variability of wood, moisture absorption rate of the wood, and panel variables such as species and orientation of veneers or strands. Some of these inherent panel properties are linked to the natural characteristics of wood and are generally either impossible or impractical to control. Therefore, the user should attempt to prevent high moisture conditions by providing adequate ventilation, and also to minimize the effects of moisture by using recommended panel joint spacing and adequate fastening.

Design and Construction Features That Reduce Buckling

Moisture Control

The first step in the prevention of sheathing buckling is to provide adequate moisture control. Ventilation requirements for attics and roof structural spaces, as well as crawl spaces, are covered in the building codes. In the 2024 International Building Code (IBC) Section 1202.2, the minimum net free ventilating area is required to be 1/150th of the area of the space ventilated except that the ventilation may be reduced from 1/150th to 1/300th if both of the following conditions are met:

1. In climate zones 6, 7 and 8, a Class I or II vapor retarder is installed on the warm-in-winter side of the ceiling.
2. At least 40% and not more than 50% of the required venting area is provided by ventilators located in the upper portion of the attic or rafter space. Upper ventilators shall be located not more than 3 feet below the ridge or highest point of the space, measured vertically, with the balance of the ventilation provided by eave or cornice vents. Where the location of wall or roof framing members conflicts with the installation of upper ventilators, installation more than 3 feet below the ridge or highest point of the space shall be permitted.

In addition, the 2024 IBC contains provisions that require the placement of blocking and bridging in such a way as to not interfere with air movement.

In the 2024 International Residential Code (IRC) Section R806.2, however, the minimum net free ventilation area may be reduced from 1/150th to 1/300th of the ceiling area, providing both of the conditions below are provided:

- In climate zones 6, 7 and 8, a Class I or II vapor retarder is installed on the warm-in-winter side of the ceiling.
- At least 40% and not more than 50% of the required ventilating area is provided by ventilators located in the upper portion of the attic or rafter space. Upper ventilators shall be located no more than 3 feet below the ridge or highest point of the space, measured vertically. The balance of the required ventilation provided shall be located in the bottom one-third of the attic space. Where the location of wall or roof framing members conflicts with the installation of upper ventilators, installation more than 3 feet below the ridge or highest point of the space shall be permitted.

Refer to APA Technical Note: *Condensation Causes and Control*, Form X485, for further details.

Note that these are minimum code requirements, which have been found to be adequate under most normal circumstances. However, ventilation in excess of these minimums may be necessary when unplanned moisture is introduced, as by venting an appliance, such as a clothes dryer, into the attic (not recommended), or when moisture-laden air is introduced to the attic by whole-house fans.

What may normally be adequate attic ventilation is sometimes inadvertently made ineffective due to poor construction practices during new construction, remodeling or retrofit. It is not uncommon to find the ceiling insulation blocking off the soffit vents. Baffling should be provided at the eaves to prevent the insulation, particularly loose-fill types, from drifting over the vent openings. Another poor practice is to vent kitchens or bathrooms directly into the attic, adding extra moisture-laden air that must be exhausted to the outside by ventilation. Instead, such venting should be ducted all the way through the roof or walls to the outside.

Some construction features, such as flat roofs, don't lend themselves to good circulation even where code-required vent openings are provided. In these cases an efficient ceiling vapor barrier/retarder is essential. This vapor barrier/retarder should be installed so that any penetrations, such as light fixtures, are carefully sealed by caulk or tape to prevent moisture-laden air movement from the interior of the building.

Panel Installation

Sheathing panels require aligned, level framing for a nailing surface. Any misalignment between adjacent trusses or rafters will cause the panel to bend, resulting in a wavy appearance. Many reported claims of panel buckling have, upon thorough field inspection, been traced to misaligned trusses, rafters or wall framing. Misalignment of trusses or rafters can occur from faulty truss fabrication, poor workmanship during construction, or from warping, shrinking or swelling of lumber after construction. Regardless of the cause, misaligned trusses, rafters or wall framing impact the long-term appearance of wood structures.

It is important that end and edge joints be properly spaced during sheathing installation. No matter what steps are taken to protect or seal panel faces and edges, panels will expand or shrink slightly with changes in moisture content. If expansion is prevented by tightly butted joints, resulting compression of the panel could lead to buckling. Spacing of 1/8 inch is recommended at all panel edges and ends, or as required by the panel manufacturer^a.

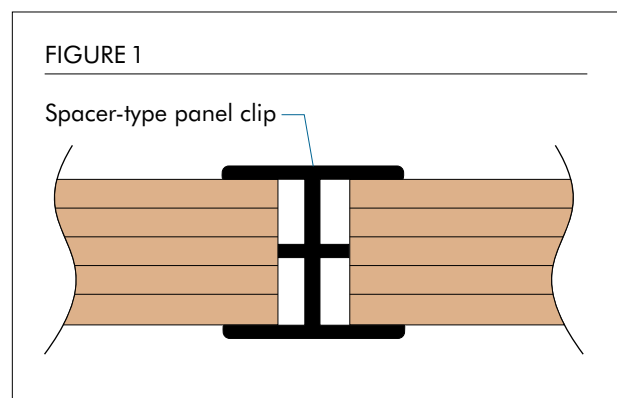

a. Panel spacing is an **APA RECOMMENDATION**, but not a code requirement^b, to provide installers with a means of minimizing the potential for panel buckling, which can lead to an unsightly appearance and customer complaints. Panel buckling may be an aesthetic or serviceability issue but is not a structural deficiency. There is no reason to expect this recommended space to be maintained when the panels become acclimated. Gaps that were initially present may have closed due to normal moisture-related expansion. If the flatness of sheathing or flooring panels is acceptable, APA would generally recommend that any finish flooring, siding or roofing be installed as planned — regardless of whether gaps are present.

b. Some manufacturers may require a space at the time of installation.

Use of spacer-type panel clips, as shown in Figure 1, will assist in obtaining proper edge spacing of roof sheathing. Some builders fashion a spacer tool or use a 10d box nail to ensure proper spacing.

Close attention should be paid to proper nail size and spacing and, of course, to assure that fasteners do not miss the supports. Fasteners should be 3/8 inch from panel ends and edges. For ordinary sheathing applications, nail spacings of 6 inches o.c. at all supported edges and 12 inches o.c. at intermediate supports have been found adequate to hold panels flat under most conditions. Other nail spacings may be required for high wind areas, engineered roof diaphragms or shear walls.

For walls that are already standing, the sequence of panel sheathing nailing can also be a factor in maintaining a uniformly flat appearance. The following sequence avoids building an internal compression stress into wall sheathing. First, position the panel, maintaining recommended edge spacing, and lightly tack at each corner. Install the first row of nails next to the preceding panel from top to bottom. Remove remaining tacking nails. Then nail the row at the first intermediate stud. Continue by nailing at the second intermediate stud, and finally, at the edge opposite the preceding panel. Complete the installation by fastening to the top and bottom plates or intermediate blocking.

To the extent possible, structural panel sheathing should be protected from direct moisture, both before and after installation. Cover roof sheathing with shingle underlayment (ASTM D226 Type 1, ASTM D4869 Type 1, ASTM D6757 or ASTM D1970) as soon as possible to minimize roof sheathing exposure to weather, unless otherwise recommended by sheathing manufacturer. Further equilibration with surrounding air is desirable prior to application of the roof covering (consult shingle manufacturer's recommendations).

Special Considerations

Note that when one or more of the following factors are present, additional techniques should be considered to help ensure best performance:

- Shear wall or diaphragm applications with edge nail spacing 4 inches o.c. or closer, and panels applied parallel to supports
- Use of three-ply plywood panels with face grain parallel to supports (i.e., walls)
- Use of oversized panels, such as 8 feet x 8 feet panels in panelized roof applications
- Panels installed within a few days of their manufacture
- Extended rainy weather where panels may become saturated with water

These applications can be high buckling risk because the conditions may reduce the standard panel edge gap's effectiveness in absorbing the panel expansion. This is because:

1. The increased nailing schedule in some diaphragms and shear walls may essentially prevent any panel expansion.
2. Low panel stiffness in spans between the supports can lead to buckling from relatively low moisture-induced axial loads.

3. An oversize panel dimension allows panel expansion to build up.
4. To facilitate proper gluing, all panels are very dry at the time of manufacture — a condition that can lead to higher-than-expected expansion after the panels are in place.
5. During long periods of wet weather, panels may pick up more moisture than anticipated by the normal 1/8-inch spacing recommendation.

For these applications, the following techniques help offset the increased buckling risk:

Panel Conditioning: An effective step in the prevention of panel buckling is to condition the sheathing panels **whenever possible** to the building environment before installation. Including this step could reduce the amount of additional moisture absorption after panels are installed, thereby reducing dimensional expansion between installation and end-use conditions, which in turn reduces buckling risk. This is especially important for newly manufactured panels, which are typically very dry and have a great potential for expansion.

Panel Edge Spacing: Additional attention to edge spacing may be required to mitigate the higher buckling risk. For newly manufactured panels, if the panels were not acclimated before installation, a 1/8-inch gap at edges and ends may be insufficient. **For example, for oversized panels and/or factory-dry panels, consider increasing the panel gaps at ends and edges to 1/4 inch.** This may require additional trimming of the panels to fit the framing module or by specifying a special size from the panel manufacturer (such as 1/4-inch undersized).

Panel Nailing: In applications where high-density nailing schedules are followed, such as some diaphragms and shear walls, simple edge gapping may not be effective. To allow for expansion of more densely nailed panels (nail spacing 4 inches o.c. or closer) and for panels subject to total jobsite water saturation, the following nailing sequence should be considered:

- Temporarily nail panels with a nail spacing of 12 or 24 inches o.c. at ends, edges and intermediate supports (rather than at the closer, specified shear wall or diaphragm schedule) during the framing phase of construction. For this initial nailing, use the nail size specified. With this lighter-than-specified nailing schedule, resultant panel expansion is more readily accommodated by the panel edge gaps.
- After the panels become acclimated to jobsite moisture conditions and immediately prior to covering with siding or roofing, complete final nailing. Be aware that when the spaces between the panels close as the panels become acclimated, finish roofing materials installed too early in the moisture-absorption process may buckle upward over the closing panel-joint spaces. Waiting until the panels have absorbed the moisture will minimize the potential for shingle ridging or other types of buckling over panel joints.

Correction of Panel Buckling

Suggestions for repair of roof shingle buckling are provided by shingle manufacturers or the [Asphalt Roofing Manufacturers Association](#). Otherwise, if buckling has occurred, assure first that waviness is not actually caused by poor alignment or warping of framing members. Misaligned trusses, rafters or wall framing make the sheathing appear wavy as if it has buckled. Check for proper alignment by using a taut line or straightedge. Also verify that the panels are properly fastened to the framing.

If panel buckling has indeed occurred, attempt to identify and correct the cause of increased moisture conditions. For example, if roof sheathing buckled prior to roofing, high moisture content due to extreme weather and/or inadequate spacing of panel joints may have been the cause. Once corrected, buckling would not be expected to happen again. However, if buckling occurs after roofing and after the building is occupied, excessive moisture from within or inadequate ventilation should be suspected and the cause located and corrected.

No technique has yet been identified as 100% effective in correcting buckling once it has occurred. However, several techniques have met with some success:

1. Space heaters or fans may be used to dry sheathing quickly. Some recovery may be expected, perhaps enough to be acceptable.
2. Tightly butted edges or ends of structural panels may be saw-kerfed to relieve pressure and provide a gap for expansion.
3. Blocking may be added under unsupported panel edges or under buckled areas. Sheathing may then be flattened by nailing or screwing to the blocking.
4. A panel clip may be inserted at the joint between buckled roof sheathing panels to bring them into alignment. This may be done by cutting a small hole at the joint with a hole saw, as shown in Figure 2, inserting the clip and sliding it to the location desired. Where roofing has already been applied, align panels by installing a cleat with screws from below, as in Figure 3.

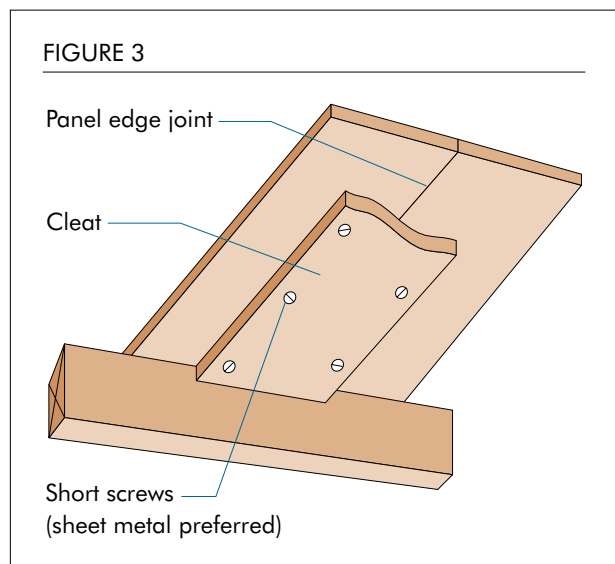
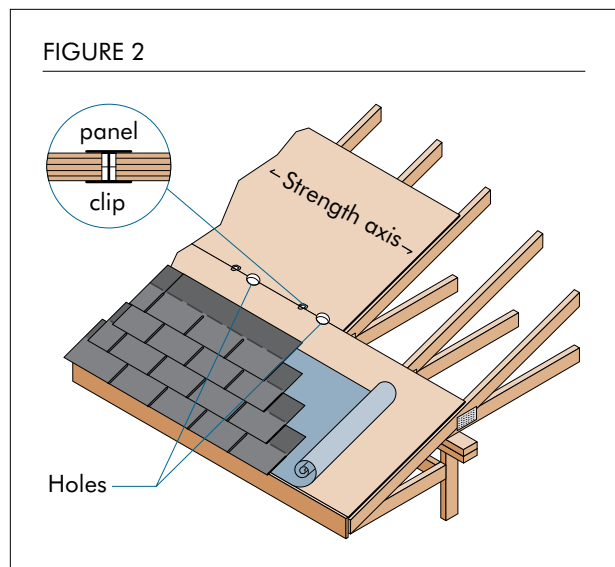

5. Where buckling occurs between fasteners, more fasteners may be added to bring the panel down to supports. If buckling between fasteners on a panel end is severe, a saw kerf might be cut from the panel edge inward parallel to the strength axis for a short distance to relieve pressure, as shown in Figure 4.

References

APA Builder Tips: *Prevent Buckling with Proper Spacing*, Form M300

APA *Engineered Wood Construction Guide*, Form E30

APA Technical Note: *Jumbo Panels for Nonresidential Roofs*, Form W220

APA Builder Tips: *Storage and Handling of APA Trademarked Panels*, Form U450

APA Technical Note: *Condensation Causes and Control*, Form X485

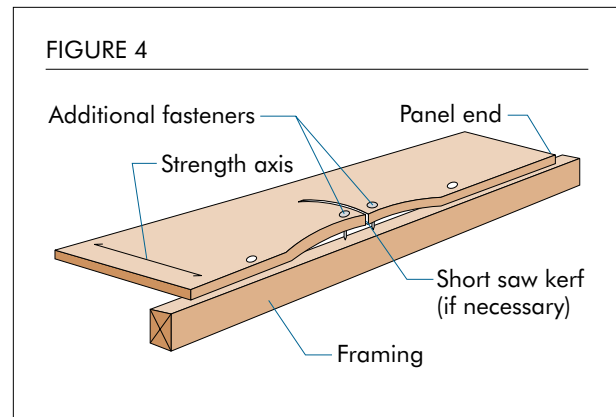

Minimizing Buckling of Wood Structural Panels

We have field representatives in many major U.S. cities and in Canada who can help answer questions involving APA trademarked products. For additional assistance in specifying engineered wood products, contact us:

APA HEADQUARTERS

7011 S. 19th St., Tacoma, WA 98466
(253) 565-6600 ■ Fax: (253) 565-7265

PRODUCT SUPPORT HELP DESK

(253) 620-7400 ■ help@apawood.org

DISCLAIMER

The information contained herein is based on APA – The Engineered Wood Association’s continuing programs of laboratory testing, product research and comprehensive field experience. No warranties, express or implied, including as to fitness for a particular purpose, are made regarding this publication. Neither APA nor its members shall be liable, or assume any legal liability or responsibility, for damages, direct or indirect, arising from the use, application of, and/or reference to opinions, findings, conclusions or recommendations included in this publication. Consult your local jurisdiction or design professional to assure compliance with code, construction and performance requirements. Because APA has no control over quality of workmanship or the conditions under which engineered wood products are used, it cannot accept responsibility for product performance or designs as actually constructed.

Form No. D481P/Revised July 2024

© Copyright. 2024. APA – The Engineered Wood Association. All rights reserved. No part of this publication may be reproduced, distributed, transmitted, displayed, or published without prior written permission of APA. No part of this publication may be entered, input, or used to teach or train a machine learning or artificial intelligence tool or system.



REPRESENTING THE ENGINEERED WOOD INDUSTRY